

# PROFIRE 1100

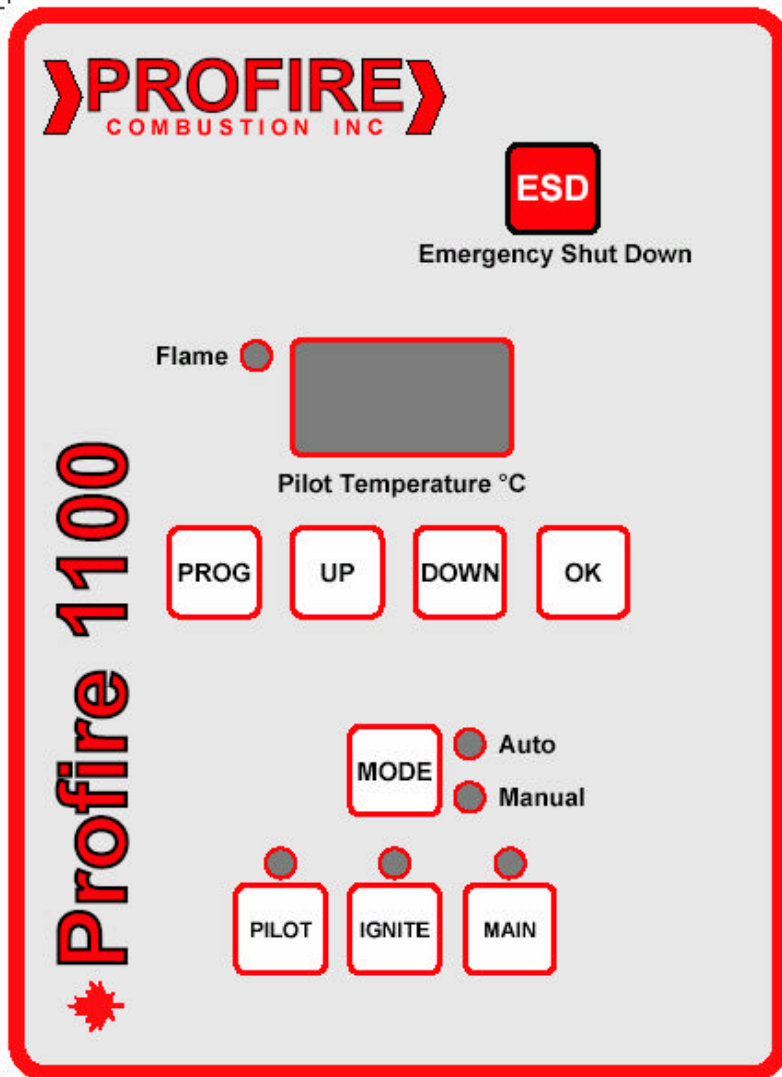

**IGNITION FLAME SAFETY CONTROLLER**

REV 3

## Cautions

### **WARNING:**

**EXPLOSION HAZARD - -DO NOT SERVICE UNLESS AREA IS KNOWN TO BE NON-HAZARDOUS**

**-DO NOT OPEN WHEN ENERGIZED**

**EXPLOSION HAZARD - -SUBSTITUTION OF COMPONENTS MAY IMPAIR THE SUITABILITY FOR ZONE 2 (Class 1 Division 2)**

**-REPLACEMENT FUSES MUST BE SAND-FILLED**

## INSTALLATION WARNING

### **Terminal Connections:**

**Connections must conform to the directions in this manual.**

**The unit must be properly connected to earth-ground for effective ionization operation.**

**Electrical devices connected to the controller must meet electrical standards and be within voltage limits.**

### Contact Number

**For any questions call:**

**780-960-5278**

# Table of Contents

Introduction	1	Operation	13
Features	2	Operation	14
Specification	3	Thermocouple	15
Installation	4	Message Codes	16
Hook-up drawing	5	Error Codes	17
Terminal Connection	6		
Coil	7		
Pilot hook-up	8		
Key-pad	9		
Menu	10		
Menu functions	11		
Set-up	12		

---

## **Profire 1100 Operation**

### **Overview**

**The Profire 1100 is a burner ignition system for atmospheric natural-draft burners. The unit monitors and controls a pilot valve, main burner valve, uses high-voltage spark ignition and has inputs to shutdown the burner or prevent startup if there is a fault condition. The method of flame detection is ionization, with thermocouple being used as a flame detection backup. The thermocouple is also used to control the main valve opening.**

**With ionization flame detection, the flame ionization effect is monitored between the sparker rod and the pilot assembly. With thermocouple, the flame is detected with a 'K' type thermocouple and there are two temperature set-points, one for pilot flame detected and the other set-point to check for a high temperature pilot (pilot quality) before the main valve is opened.**

**The front panel on the unit has LED lamps to display the state of the pilot valve, the main valve, the sparker, the mode, the flame along with a three digit display to indicate the state of the unit, purge times, and thermocouple temperature, depending on the sequence the burner is currently executing. The front panel also has a keypad for entering pilot temperature set-points, for controlling the operation mode, and has a prominent "emergency shutdown" button.**

**A purge timer allows time for natural gas to dissipate from the natural-draft burner between ignition attempts or after a flame failure. The purge timer is configurable to allow the purge time to be set to allow proper purging of the burner. The target setting of the purge timer is to allow three air exchanges before ignition. The purge time is set in 5 second increments up to 600 seconds (10 minutes).**

**There is a Lockout Input which can be connected to external devices. The Profire 1100 is programmed so the Lockout Input must be closed (normal state) before a start sequence is initiated. The Lockout Input can be connected to valve position sensors or other devices that give a closed contact when in a "safe-to-start" mode. After the unit has started the ignition sequence, the Lockout Input is allowed to open.**

**The PRS Input (pressure input) must be closed for the unit to start, as well as while the unit is in normal running mode. This input can be wired into high and low pressure switches in a loop so if any device opens its contacts, the controller will shut down the burner, initiate alarm mode, and wait for operator intervention.**

**The Emergency Shutdown input must be closed for the unit to start, as well as while the unit is in normal running mode. This input can be wired into various alarms such as "High Glycol Temperature", "Low Glycol Level", etc., in a loop, so if any device opens its contacts, the controller will shut down the burner, initiate the alarm mode and wait for operator intervention.**

**An alarm output on the unit can be connected to monitoring equipment which indicates whether the unit is operating normally or has a fault.**

## Features

### **CSA:**

- **Zone 2 (Class 1, Division 2) locations approval (CSA 213-92).**
- **Burner Safety approval (CSA 22.2-199).**
- **Industrial Process Equipment approval (CSA 14-95).**

**Input Power +10 to +28 VDC.**

**Dual Flame-sensing for safety:**

- **Flame Rod (ionization circuit)**
- **Thermocouple (type K thermocouple).**

**Rapid 1.8 second shut-down on flame-out.**

**DC Voltage spark generator.**

**Low-power design to incorporate solar panels or TEG applications.**

**Auto relight or manual operation, push button selectable.**

**Remote Start/Stop control.**

**Remote ESD contact**

**Pressure Switch monitoring**

**Large, easily-accessible terminal connections.**

**Equipped with AVD (Advanced Visual Display) for improved operating functions and signals.**

**Programmed purge times, auto restart, and restart tries.**

**START-LOCKOUT input for connections to safety interlock devices.**

**All circuits are transient protected and are fail-safe.**

**Alarm contact output.**

## Specifications

### ENCLOSURE

---

**Fiberglass 8" x 6" x 4"**

**CSA and UL compliant for Zone 2 (Class 1, Division 2) locations**

**Enclosure type 4, 4X, 12, 13**

### CIRCUIT BOARDS

---

**All solid state**

**CSA compliant for Zone 2 (Class 1, Division 2) locations**

### IGNITION BASE AND COIL

---

**For non-hazardous area only**

### POWER REQUIREMENTS

---

**+10 to + 28 volts DC**

### SUPPLY CURRENT

---

**2.0 amps surge (limited), 0.015 - 2 amps run**

### POWER CONSUMPTION

---

**1100 only:**

**12 volts - Display on - 106 ma or 1.3 watts**

**12 volts - Display off - 43 ma or 0.6 watts**

**24 volts - Display on - 66 ma or 1.6 watts**

**24 volts - Display off - 35 ma or 0.9 watts**

---

\* Constant current solenoids add power required by solenoid manufacturer.

\* Power output to solenoids, Max = 30 Watts/solenoid.

**Operating Conditions: -40°C to +55°C**

---

## Installation

### Site Selection

**The Profire 1100 system enclosure is CSA compliant for a Zone 2 (Class 1, Division 2) (C&D) area classification. This means the system enclosure must be mounted outside any Zone 1 (Class 1, Division 1) area. The system can be mounted on the unit skid or on a building wall as long as it does not infringe on a Zone 1 (Class 1, Division 1) area.**

**The Profire 1100 system enclosure is a fiberglass box, 8" x 6" x 4", complete with mounting tabs. The enclosure weighs less than 5 pounds, so heavy-duty supports are not required, but the unit should be firmly mounted, as the push buttons on the front panel have to be operated. The enclosure should be mounted in a location that faces away from the burner housing so that the operator is facing both the enclosure and the burner housing while operating the unit. Other considerations are panel access, traffic, wire-runs, and visibility. The enclosure should be mounted about 5 1/2 feet above ground level.**

**The spark generator (coil), however, must be mounted in a non-hazardous area, as there is a potential of a spark arcing across the output terminals of the coil or along the insulated high-voltage leads. The ideal location for the spark generator is inside the burner housing.**

# Hook-Up drawing

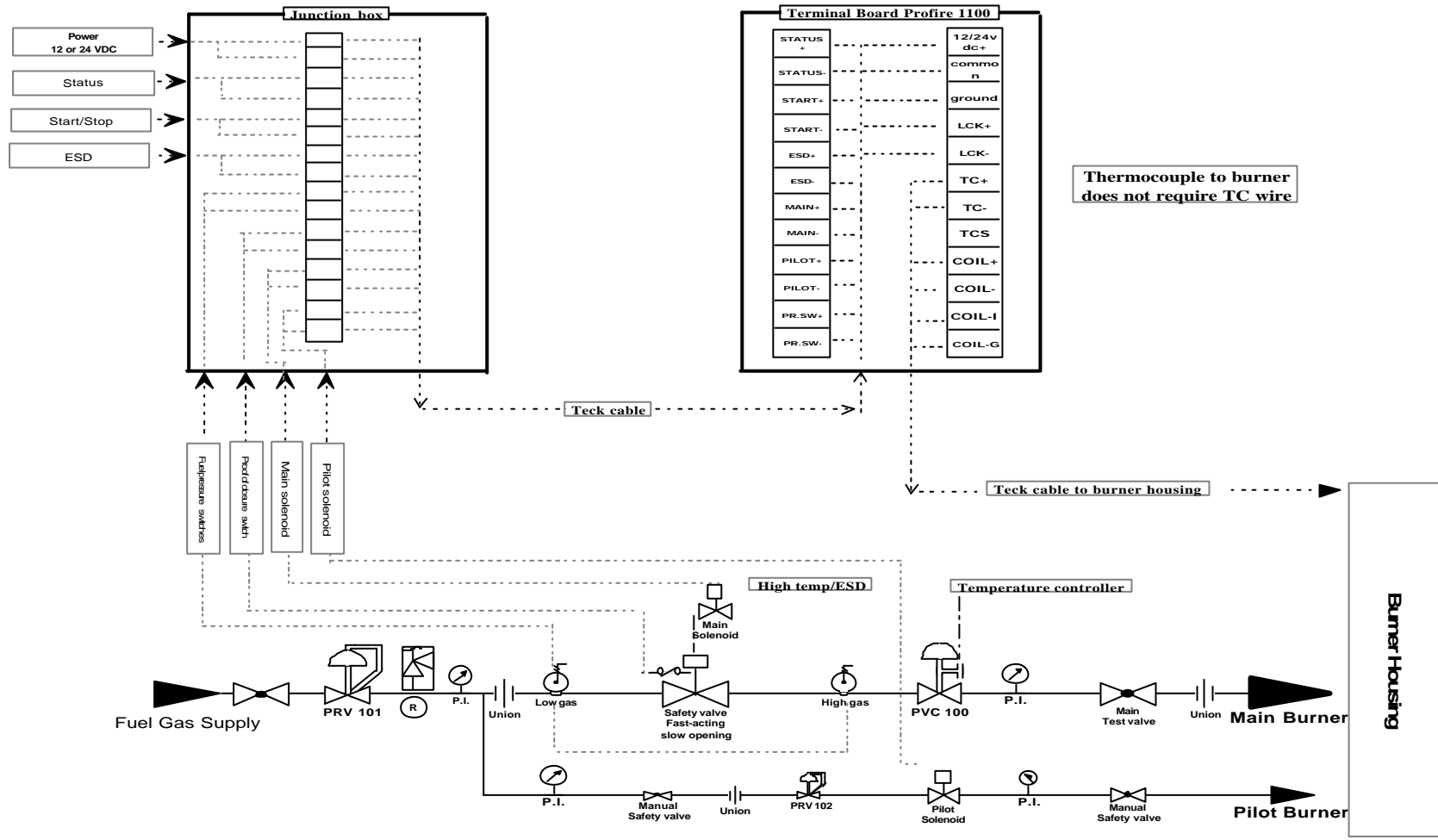

Thermocouple to burner does not require TC wire

## Terminal board connection for the Profire 1100

For good connections, spade connector should be used and wires should be clearly marked.

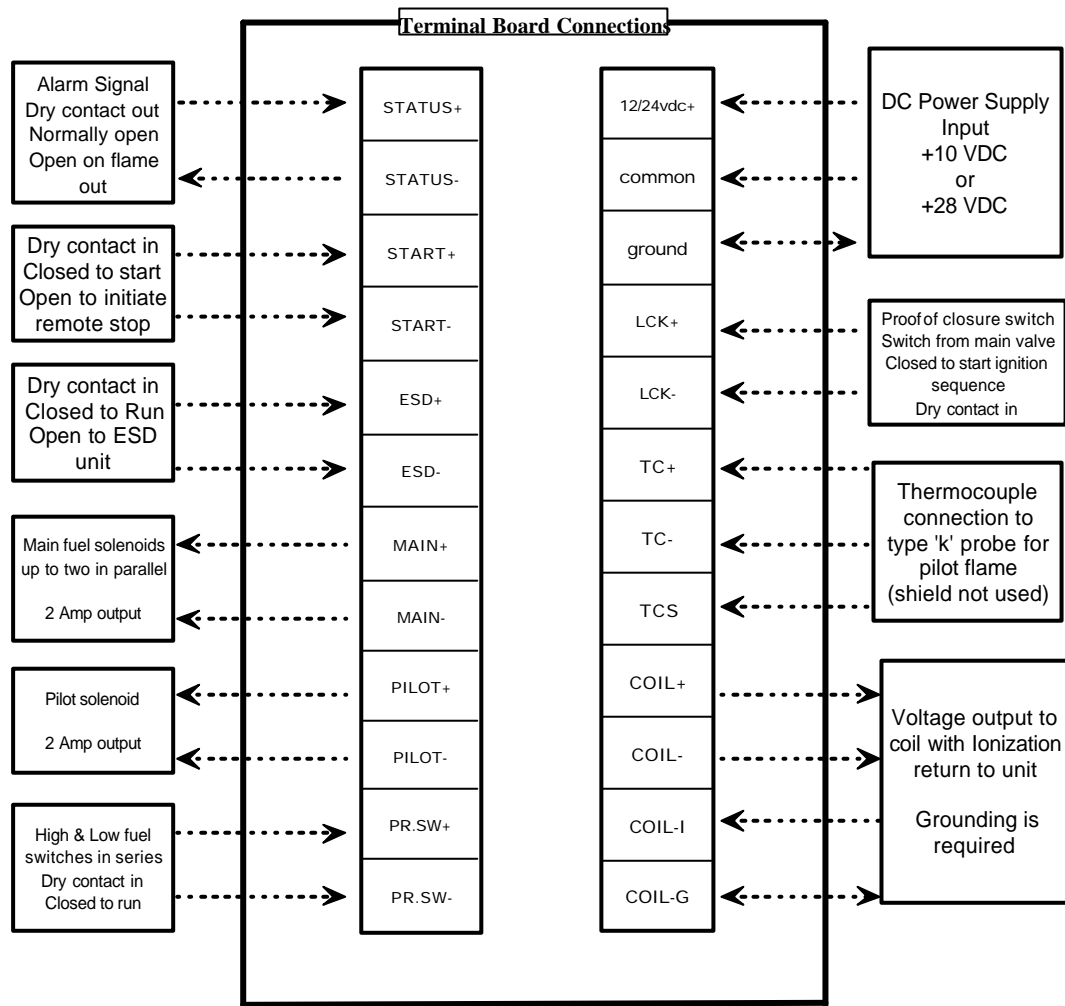

**Rev 3.B  
Version**

**\* Coil must be mounted in a NON-HAZARDOUS location.**  
Coil requires solid ground from Profire 1100 to ensure ionization operates properly.

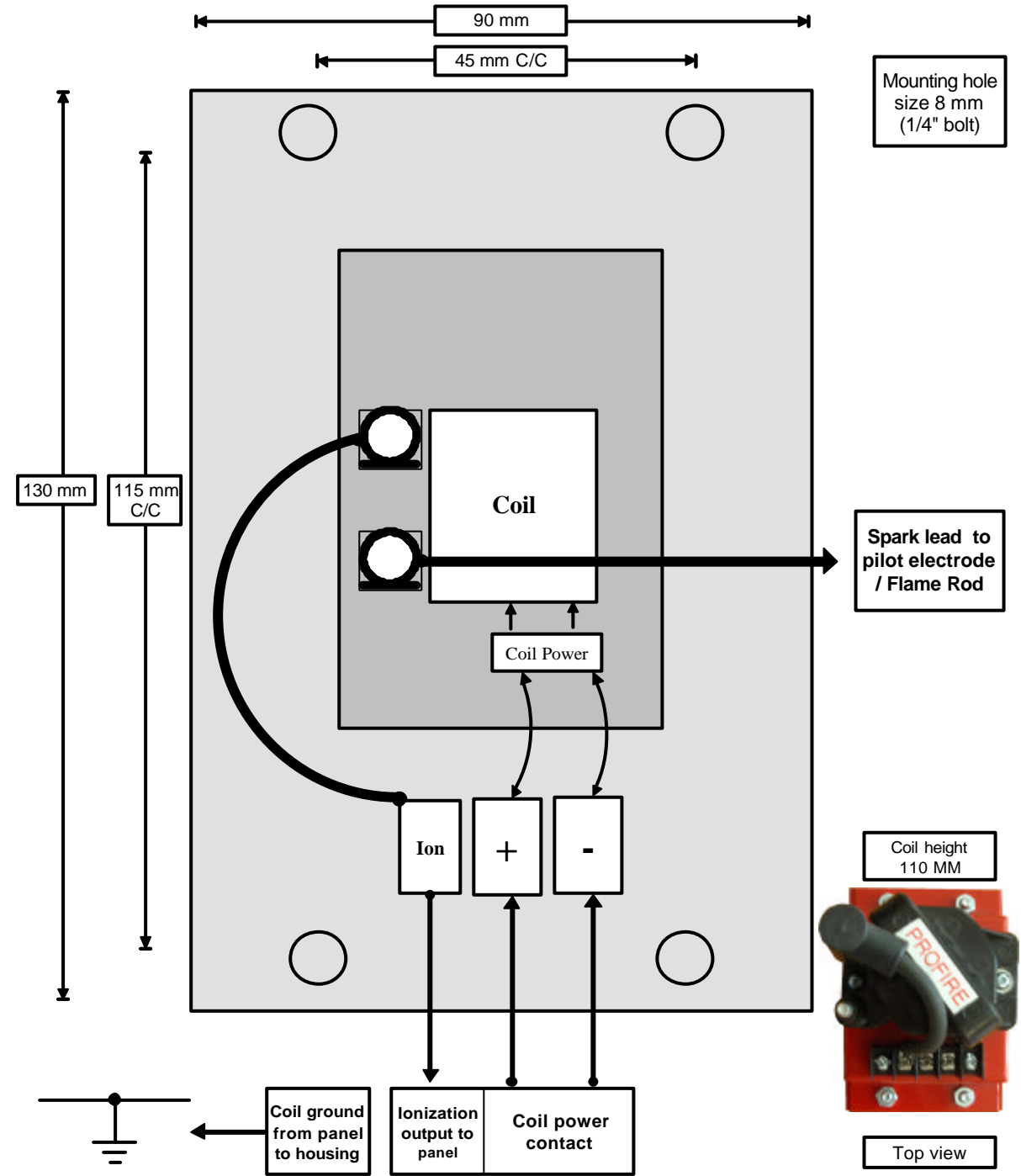

## Pilot bracket assembly

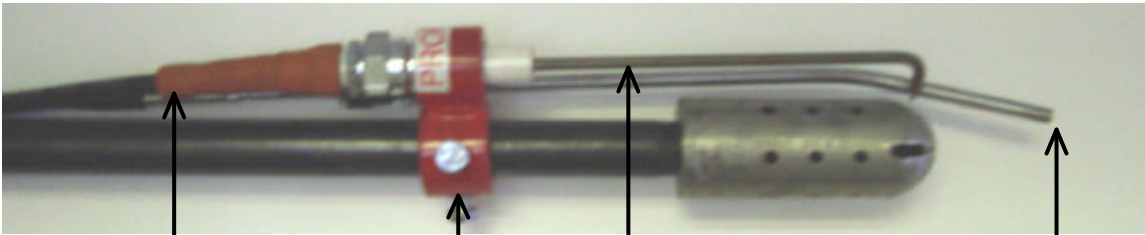

Pilot mounting bracket.  
Standard size for 1/2" pipe.  
Comes with electrode bushing  
and probe fitting.

Type "K" thermocouple probe  
2" past pilot nozzle with a 30°  
bend

Ignition cable. Five foot carbon lead  
with end connections for electrode  
and coil.

Kanthol electrode, ignitor and  
flame rod. Bend in a fashion  
that the gas will ignite.

Pilot bracket assembly can be mounted on existing pilot. Brackets can be ordered to fit pilots 1/2" and up. Slip-stream applications are also acceptable, but may require custom length probe and ignition electrode.

Pilot burner is **not included** with standard system  
Available as option

## Key-pad function

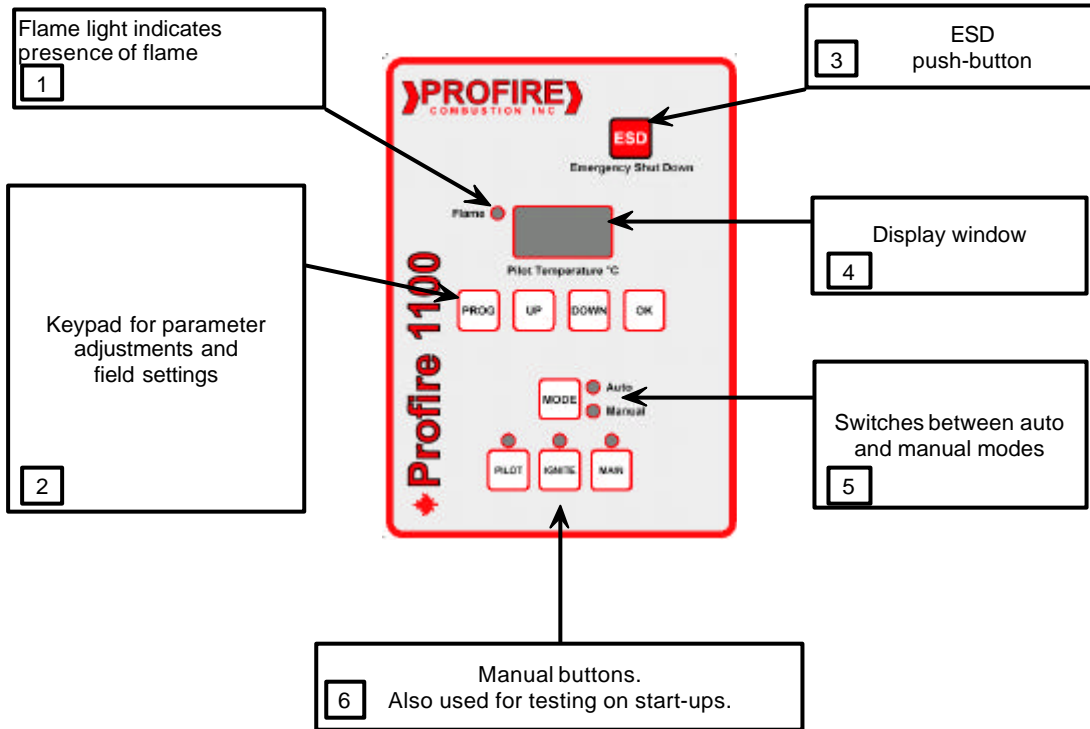

1	Flame light indication: Allows operator to see that the pilot is lit.
2	Key-pad: Allows operator to select adjustable field parameters on the unit. Pressing the PROG button scrolls through the menu. UP and DOWN button adjusts the value or selects parameters. OK button accepts and stores the change. OK button is also used to exit the field parameter menu.
3	ESD: Allows operator to manually shut unit down and alarm.
4	Display window: Allows operator to read pilot flame temperature, menu, and errors that have occurred.
5	Mode: Allows operator to switch unit into a manual mode to check pilot ignitor and pilot solenoid, providing all safety interlocks have been met. LED's indicate the state the unit is in.
6	<p>PILOT button: Allows operator to open pilot solenoid for a period of time (45 sec) in Manual mode.</p> <p>IGNITE button: Allows operator to activate ignition providing all safety parameters are met.</p> <p>MAIN button: Allows operator to open Main only when pilot has been proved and stable.</p>

## Program Mode

On Screen	Description	Function	Default setting
<b>AU</b>	<b>Enables unit to automatically start on power-up</b>	<b>ON= Auto start enabled OFF = Auto start disabled</b>	<b>Off</b>
<b>PU</b>	<b>Purge time cycle</b>	<b>Time in seconds set for purge</b>	<b>10</b>
<b>LED</b>	<b>Allows unit to turn display off</b>	<b>ON=display always on OFF=display off after 10 min Press OK to turn on for 10 min</b>	<b>ON</b>
<b>HI</b>	<b>High set point</b>	<b>Signal setting for a fail point</b>	<b>600</b>
<b>LO</b>	<b>Low set point</b>	<b>Signal setting for a prove point</b>	<b>200</b>
<b>RE</b>	<b>Restart attempts</b>	<b>Number of times the unit will try to relight before alarming</b>	<b>3</b>
<b>AL</b>	<b>Alarm type</b>	<b>1 : Unit <u>will not</u> alarm if remote stopped 2 : Unit <u>will</u> alarm if remote stop 3 : Alarm follows main solenoid</b>	<b>1</b>

# Program Menu

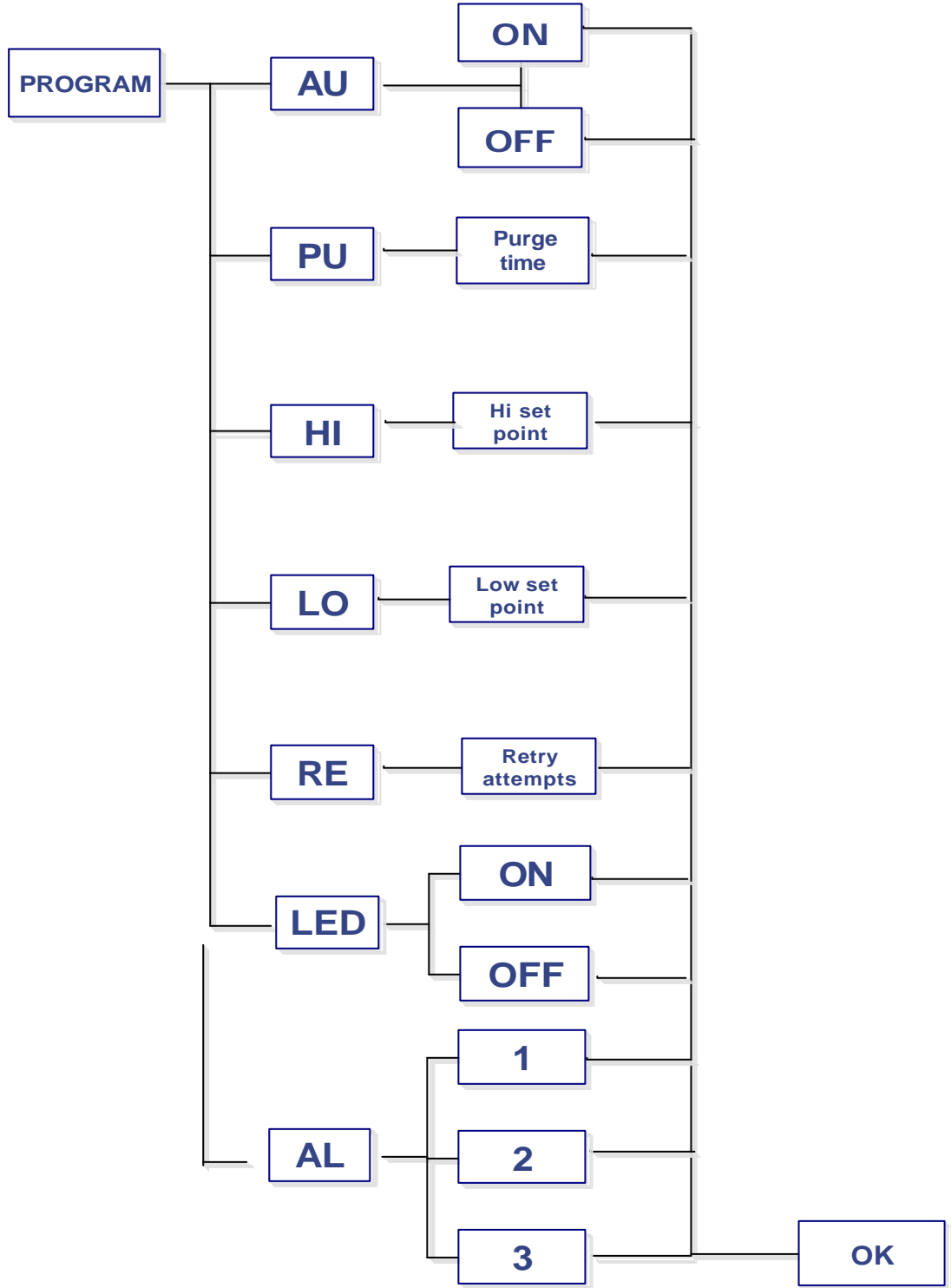

## Changing settings

**Changing settings can only be done when unit is in Manual mode.**

Using the front keypad buttons, press **PRG** to enter program mode. Repeated pressing of the **PRG** button scrolls through the menu items. Pressing the **UP** or **DOWN** buttons will modify the item selected. Press **OK** to save and exit program mode.

## Flame mode

The Profire 1100 use two methods of flame detection, using an Ionization circuit, in conjunction with a type K thermocouple probe. This is a safe and reliable method. The thermocouple probe provides a low and high set point that ensures a stable pilot. Running the Ionization circuit in conjunction with the probe, detects a flame-out within 1.8 seconds.

## Hi and Low set points

Setting the high set points can be done once the lowest running temperature of the flame has been established. This is done on the initial start-up of the unit. Typically the pilot temperature can be used, but on occasion the main burner can cool the flame temperature of the pilot. If that is the case, one should use the lower of the two flame temperatures as a guideline to setting the Hi set point. The unit must then be shut down to adjust and accept the new value. Only under special circumstances will the low set point need adjustment. This will occur if the operating temperature of the vessel is higher than the low set point, or if the probe will not cool to a point for re-ignition. One must keep in mind that on a cold start, there is a time-frame to reach this set point.

## **Operation**

### **Start sequence: In Auto mode**

#### **Step #1**

- **Check is done to verify unit is in a safe mode to start**
  - **Pilot Closed**
  - **Main Closed**
  - **No Flame detected**
  - **Lockout input closed**
  - **PRS input closed**
  - **ESD input is closed**

#### **Step #2**

- **Sparker starts sparking and Pilot opens**
  - **Sparker sparks 20 times per second for a total of 5 seconds.**
  - **After 5 seconds of Spark, the Pilot remains open for 10 seconds for flame detection.**
  - **If no flame is detected, the Pilot is closed and the system goes into a purge delay.**
- **After the purge delay and if the retry count has not been exceeded, the unit will again try to light the burner.**
- **The unit is only allowed a set number of retries. If the retry count has been exceeded, the unit goes into Idle mode and the alarm output indicates an alarm condition. In idle mode, no additional relight attempts will be made unless there is operator intervention.**

#### **Step #3**

- **Pilot flame verification and Main valve opening**
  - **After ignition, if the pilot is verified for 10 seconds, the Main valve is allowed to open.**
  - **The pilot temperature has to reach the high setpoint before the Main will open.**
  - **If flame fails anytime during this sequence, the unit will go into a purge sequence. If the retry counter allows, it will attempt a relight; otherwise it will go into idle mode, alarm and wait for operator intervention.**

#### Step #4

- **Burner running**  
If flame is lost for 1.8 seconds, the main and pilot valves will close and the burner will go into a purge sequence. If the retry counter allows, it will attempt a relight; otherwise it will go into idle mode, alarm and wait for operator intervention.
- If the thermocouple temperature drops below the high setpoint, the main and pilot valves will close and the burner will go into a purge sequence. If the retry counter allows, it will attempt a relight; otherwise it will go into idle mode, alarm and wait for operator intervention.

#### Notes:

- On unit power up, the unit will first go into a purge cycle, then if in Manual mode the unit will wait for operator input or if in Auto mode, the unit will attempt an ignition sequence.
- During an Emergency Shutdown (ESD), the LED display digits show “ESD”, the unit will shut down, and the unit will switch to Manual mode. To clear ESD, the operator must press the OK button. If the unit will not clear, the ESD contact is still open. In this case, check plant condition.
- If the Lockout Input opens during the start sequence, the unit will display LCK, prevent startup, and wait for the operator to press OK. If the LCK does not clear, then the contact is still open and the operator should check the valve or limit-switch position.
- If the PRS Input opens at any time, the unit will shutdown, display PRS, and wait for the operator to press OK. If the unit does not clear, check pressure switches.
- During the purge time, the unit is prevented from ignition or valve operation until the timer reaches zero. The LED display digits will display “PU” alternating with the time left on the purge timer.
- In normal operation, the display will show the thermocouple temperature. There is a configuration option to turn off the display and indicator LEDs after a time, to save power.
- If the thermocouple is disconnected, the unit will flash 999 and prevent startup.
- When the burner is operating normally the display will show “RUN”.

**\* During anytime, if the ESD button is pressed or the ESD input opens, the unit shuts down the burner, goes into Alarm mode, and will not attempt any relights.**

Function Diagram 1

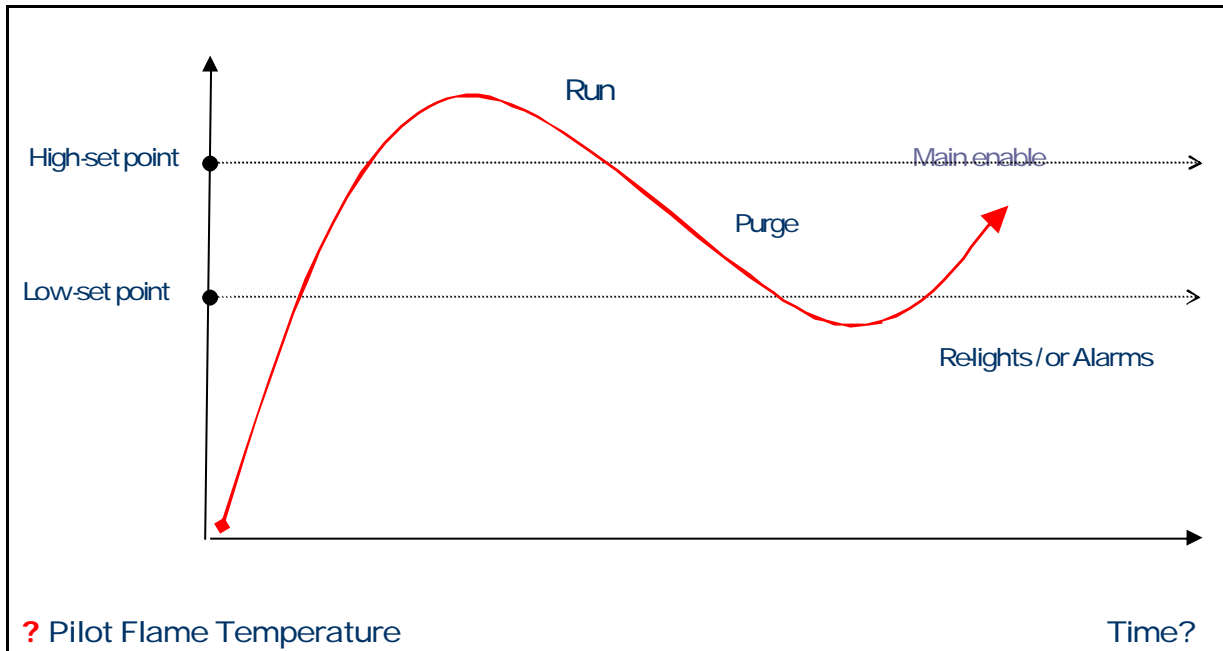

Type 'K' Thermocouple Output Chart

TEMP °C	TYPE K MV	TC OUTPUT	TEMP. °C	TYPE K MV	TC OUTPUT
40	1.611	.401	560	23.198	5.740
60	2.436	.605	<b>600</b>	<b>24.902</b>	<b>6.161</b>
100	4.095	1.015	640	26.599	6.581
140	5.733	1.420	660	27.445	6.790
160	6.539	1.620	700	29.128	7.206
<b>200</b>	<b>8.137</b>	<b>2.015</b>	740	30.799	7.619
240	9.745	2.413	760	31.629	7.825
260	10.560	2.614	800	33.277	8.232
300	12.207	3.022	840	34.909	8.636
340	13.874	3.434	860	35.718	8.836
360	14.712	3.641	900	37.325	9.233
400	16.395	4.057	940	38.915	9.626
440	18.088	4.476	960	39.703	9.821
460	18.938	4.686	1000	41.269	10.209
500	20.640	5.107	1060	43.585	10.781
540	22.346	5.529	1100	45.108	11.158

**Default settings are bolded.**

## Message Codes

**Always ensure proper voltage is applied; +10 to +28VDC. Earth ground is required.**

<u>Display Message</u>	<u>Cause</u>	<u>Action</u>
AU	Unit is in auto mode	No action required
LCO	Limit switch is open when ignition sequence initiated.	Ensure valve is closed and switch in proper position.
P-C	Pilot in cool down, thermocouple must cool to low set point	No action required
PRS	Fuel pressure switches open.	Ensure proper fuel pressures.
999	Check probe connections. Check probe	Replace thermocouple probe.
PU	Purging	No action required
ESD	ESD contact open or manual push button depressed	To clear, push OK
RDY	Unit is in ready state	No action required
RUN	Unit is running	Press OK to read pilot temperature
FAL	Unit has failed to start	Check pilot gas

<u>Display Message</u>	<u>Cause</u>	<u>Action</u>
<b>Err 1</b>	<b>Start sequence initiated while FLAME is detected.</b>	<b>Check pilot for flame. Reset system</b>
<b>Err 2</b>	<b>Configuration memory failure.</b>	<b>Replace door card.</b>
<b>Err 3</b>	<b>PILOT button pressed for more than 30 seconds.</b>	<b>Clear and restart sequence.</b>
<b>Err 5</b>	<b>Thermocouple connection disconnected.</b>	<b>Check Probe.</b>
<b>Err 6</b>	<b>Pilot or Main solenoid detected ON when should be OFF</b>	<b>Check solenoids. Replace bottom card.</b>
<b>Err 20</b>	<b>Internal selfcheck fault.</b>	<b>Replace door.</b>

**Note: If all the LED's are off, the unit may be configured for power-saving mode. Press OK button to turn on LED's**